

SBK-1KL

SBK-1KL SERIES IP68 STAINLESS STEEL SHEAR BEAM LOAD CELLS, 1000 Ohm



Stainless steel shear beam load cells suitable for building, for example, CE-M approved scales with 4 load cells or for weighing tanks and hoppers with the relevant accessories.

CAPACITIES (kg): 300, 500, 1000, 2000.

Stainless steel. IP68 protection. C3 precision class.

Working in cooperation with:

VAHY PRO S.R.O.

FUGNEROVA 345 - 40004 - TRMICE
Tel. 0042-0475620800 Fax. 0042-0475620800
vahypro@vahypro.cz

The best solution
for advanced industrial
applications

MAIN FEATURES

- C3 PRECISION CLASS
- STAINLESS STEEL CONSTRUCTION
- IP68 PROTECTION
- MAX. CAPACITIES FROM 300 TO 2000 kg
- SHIELDED CONNECTION CABLE
- OIML CERTIFICATE AVAILABLE UPON REQUEST
- TEST CERTIFICATE AVAILABLE UPON REQUEST

TECHNICAL FEATURES

- Minimum load cell verification interval: $V_{min} = E_{Max} / 10.000$
- Maximum number of verification intervals: $n_{LC} = 3000$
- Combined error: 0,017% of Full Scale Output (F.S.)
- Full Scale Output: 2mV/V +/- 0.1%
- Temperature effect on zero: 0,0014% /°C
- Temperature effect on full scale output: 0,0014% /°C
- Compensated Temperature Range: -10°C/+40°C
- Operating Temperature Range: -20°C/+60°C
- Creep error after 30 minutes: 0,024% F.S.
- Maximum tolerated excitation voltage: 15 VDC
- Input Resistance: $1100 \pm 50 \text{ Ohm}$
- Output Resistance: $1000 \pm 10 \text{ Ohm}$
- Insulation Resistance: >5000 MOhm
- Safe Overload: 150% F.S.
- Ultimate Overload: 200% F.S.
- 6-wire shielded cable, 5m long, 5 mm diameter

ATEX VERSION

- The CCATEX certificate makes the load cell suitable for use in hazardous areas with protection methods according to:
ATEX II 1G Ex ia IIC T6 (Ta -20÷+40°C) TX (Ta -20÷+65°C) Ga
ATEX II 1D Ex ta IIIC TX°C (Ta -20÷+40°C) TX°C (Ta -20÷+65°C) Da IP65.
The certificate includes the manual and the ATEX CE conformity declaration (available in EN, DE, FR, and IT).
- **IMPORTANT:** the certificate refers to the single load cell. For systems with more load cells, it is necessary to order one certificate for each load cell.

DETAIL 1

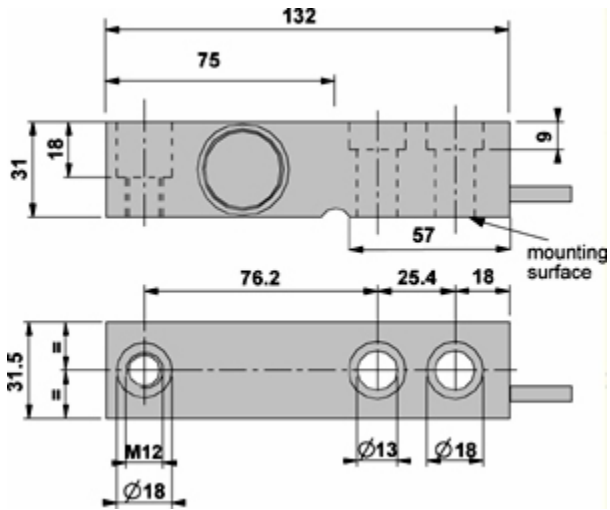





Dimensions (mm)

Wiring Code	
Colour	Function
--	SHIELD
YELLOW	OUTPUT +
GREY	SENSE +
BROWN	INPUT +
WHITE	OUTPUT -
GREEN	INPUT -
PINK	SENSE -

VERSIONS

Models Available

Code	Max (kg)	Masterpack 4 pcs
SBK300-1KL 	300	SBK300-1KLC
SBK500-1KL 	500	SBK500-1KLC
SBK1000-1KL 	1000	SBK1000-1KLC
SBK2000-1KL 	2000	SBK2000-1KLC



www.diniargeo.com



“YOUR WORLDWIDE PARTNER FOR WEIGHING,”

DINI ARGEO
FRANCE sarl
Nogent-sur-Marne

DINI ARGEO
GMBH
Sinsheim - Germany

DINI ARGEO
UK Ltd
Taunton - United Kingdom

DINI ARGEO WEIGHING
INSTRUMENTS Ltd
Shanghai - China

DINI ARGEO
WEIGHBRIDGES
Calto (RO) – Italy



HEAD OFFICE
Via Della Fisica, 20
41042 Spezzano di Fiorano Modena - Italy



VAHY PRO S.R.O.

FUGNEROVA 345 - 40004 - TRMICE

Tel. 0042-0475620800 Fax. 0042-0475620800

vahypro@vahypro.cz

SALES AND TECHNICAL ASSISTANCE SERVICE